

CURRENT 4/14

P/N: WP716 2-STAGE, 24V ELECTRIC OIL PUMP

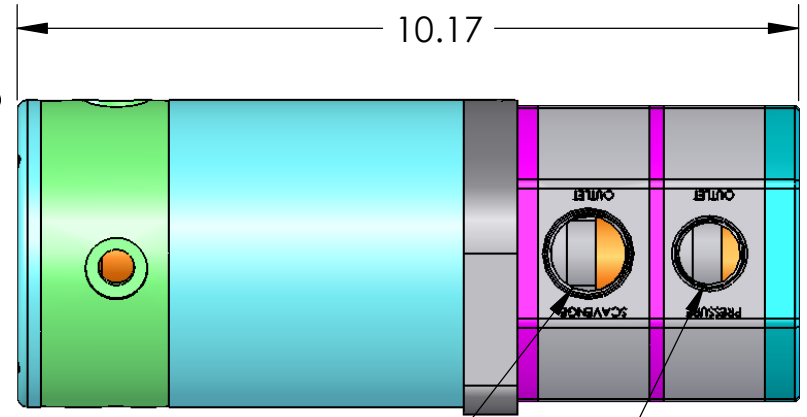
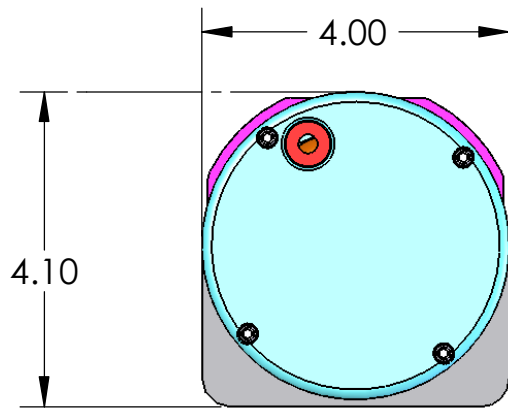

-12ANx2 THREAD
SCAVENGE SECTION

-10ANx2 THREAD
PRESSURE SECTION

PRESSURE SECTION
SCAVENGE SECTION

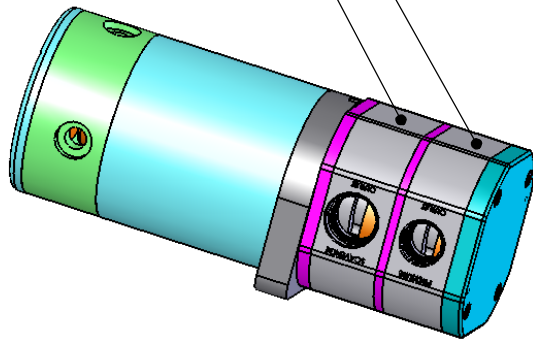

250W 24VDC BRUSH MOTOR

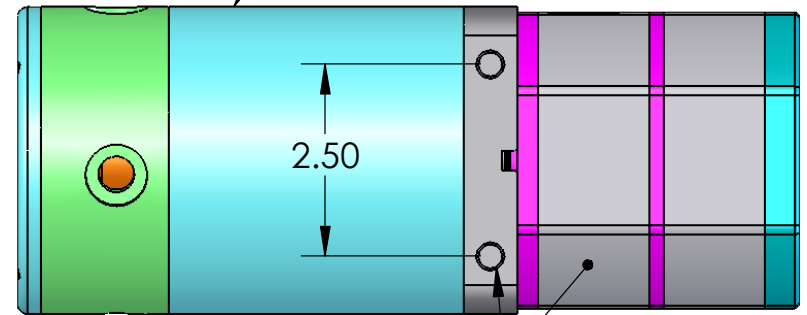

(2) x 10Mx1.5 MOUNTING HOLES

MEZIERE GEROTOR-STYLE 2-STAGE PUMP HEAD
TARGET VOLUME OF 15LPM @ 20PSIG
(SCAVENGE IS 1.2 x PRESSURE SECTION)

OTHER PUMP FEATURES:

- FLOW MAXIMUM OF >15LPM (CONTINUOUS)
- AMBIENT TEMPERATURE RATING: -20 °C TO 100 °C
- FLUID TEMPERATURE RATING: -20 °C TO 120 °C
- PWM CONTROL INTERFACE POSSIBLE
- MEETS SALT SPRAY REQUIREMENT PER ASTM-B-117
- INTENDED PUMP MEDIA: DEXRON VI ATF
- IP RATING 65

ADDITIONAL PERFORMANCE TESTING RESULTS
AVAILABLE UPON REQUEST.

OTHER TECHNICAL DETAILS: (04/01/14)

- APPROXIMATE UNIT WEIGHT: 6.8KG (15.0LB)
- PRESSURE SECTION DISPLACEMENT: 14.5CC/REV.
- SCAVENGE SECT. DISPL.: 17.6CC/REV
- RECOMMENDED MAXIMUM OUTLET PRESSURES, (SCAVENGE AND PRESSURE): 2.5 BAR
- MOTOR WATTAGE RATING (CONTINUOUS): 250W
- INTERMITTENT WATTAGE RATING (10% DUTY): 450 W (ENVIRONMENT MAY AFFECT WATTAGE RATING)
- MAXIMUM RECOMMENDED INPUT VOLTAGE: 32.0V

MEZIERE ENTERPRISES INC.

TITLE:
**ME OIL PUMPS
2-STAGE
24VDC ELECTRIC, BRUSH**

SIZE DWG. NO. REV

A WP716 - SPEC

10/8/13

SHEET 1 OF 1