

Pump Specification Sheet

Part Number: WP702

Product Weight: 5.9 Lbs.
Basic Dimensions: 5”H x 4”W x 4”D
Minimum operating Temperature: 35F
Maximum Operating Temperature: 185F
Basic Construction: Billet aluminum body, steel magnet ring, alloy steel rotors.
Seal Type: Double Lip Seal
For Media Type: Dextron II
Input Voltage: 12VDC
Expected Power Draw: See Performance Graph
Port Description (all ports): 3/8 NPT
Additional Information: This is a dual stage pump with balanced pressure and scavange.
Includes adjustable pressure regulator.

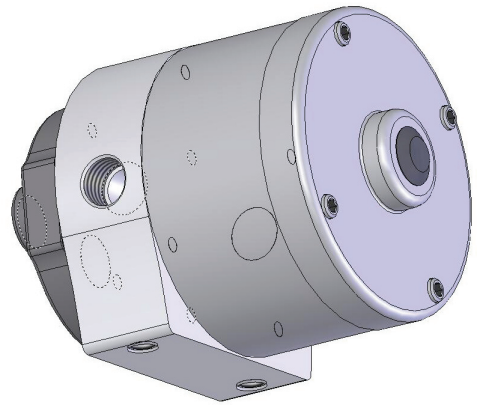
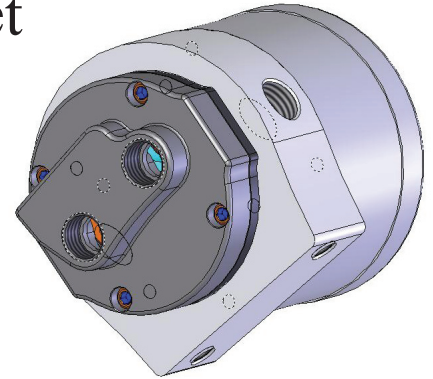

PUMP FLOW VERSUS PRESSURE @ 12 VOLTS

