

		REVISIONS			
ZONE	REV.	DESCRIPTION		DATE	APPROVED

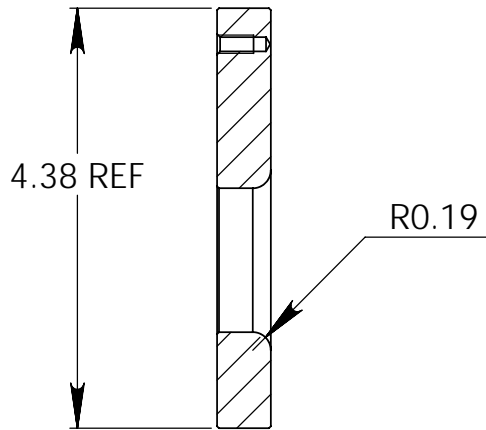

SECTION A-A

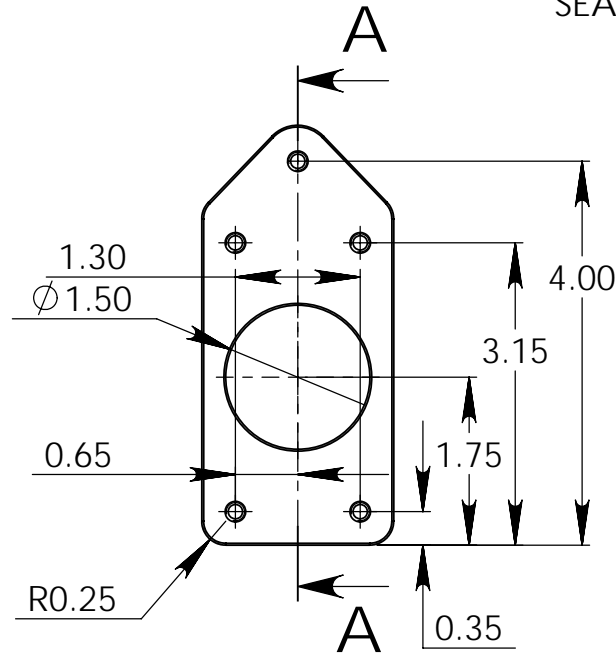

SEALING SURFACE

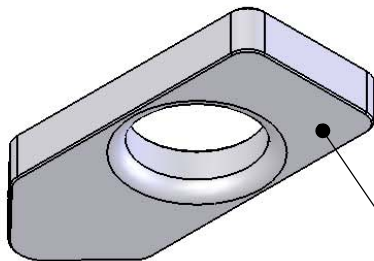
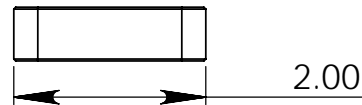
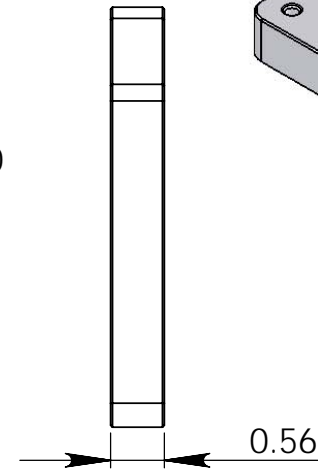
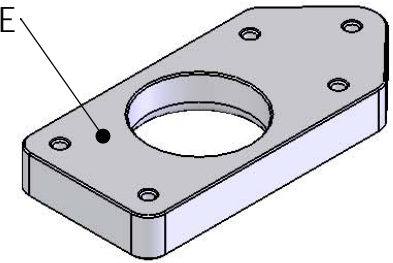

THIS SIDE TOWARD TANK

INSTALLATION NOTES:

1. WELD TO CHAMBER USING MINIMAL HEAT.
2. KEEP SEALING SURFACE CLEAN, FLAT AND FREE FROM CONTAMINATION
3. PRESSURE CHECK AFTER WELDING.

DIMENSIONS ARE IN INCHES TOLERANCES: FRACTIONAL ± 1/2 DEGREE ANGULAR: MACH ± BEND ± TWO PLACE DECIMAL ± .015 THREE PLACE DECIMAL ± .005		NAME	DATE	Meziere Enterprises Inc.		
MATERIAL	304 SS	DRAWN	DJM		ADAPTER FLANGE	
FINISH	NONE	CHECKED		SIZE		PART. NO.
DO NOT SCALE DRAWING		ENG APPR.		A	WPX820	-
		MFG APPR.		SCALE:1:2	WEIGHT:	SHEET 1 OF 1
		Q.A.				
		COMMENTS:				