

		REVISIONS			
ZONE	REV.	DESCRIPTION	DATE	APPROVED	

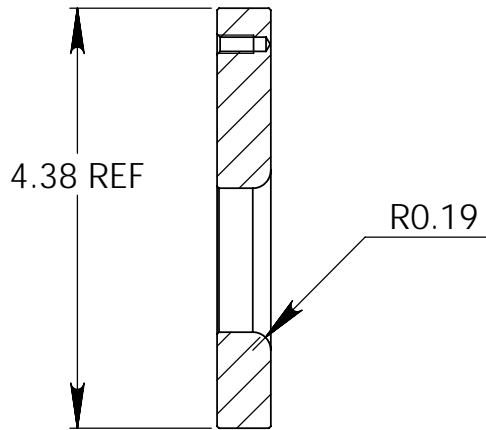

SECTION A-A

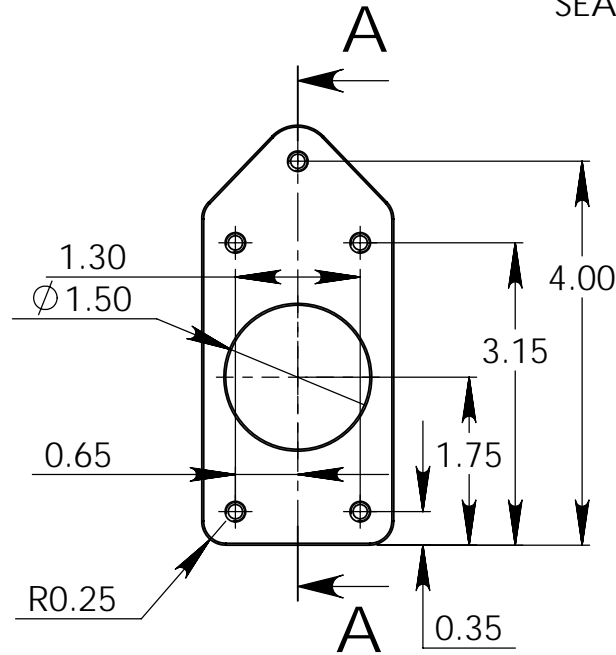

SEALING SURFACE

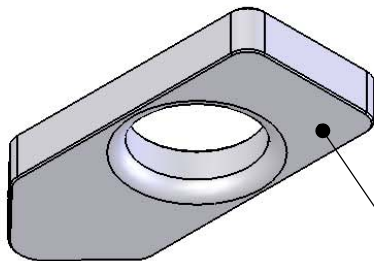
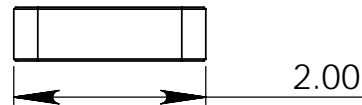
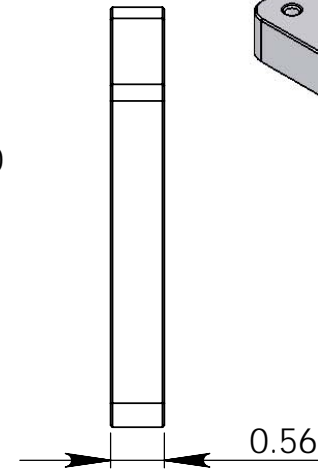
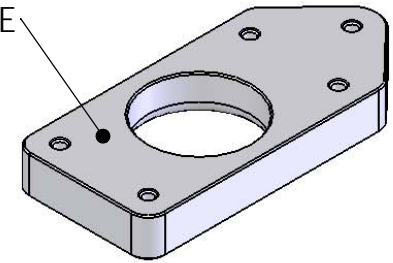

THIS SIDE TOWARD TANK

INSTALLATION NOTES:

1. WELD TO CHAMBER USING MINIMAL HEAT.
2. KEEP SEALING SURFACE CLEAN, FLAT AND FREE FROM CONTAMINATION
3. PRESSURE CHECK AFTER WELDING.

DIMENSIONS ARE IN INCHES TOLERANCES: FRACTIONAL ± 1/2 DEGREE ANGULAR: MACH ± BEND ± TWO PLACE DECIMAL ± .015 THREE PLACE DECIMAL ± .005		NAME	DATE	Meziere Enterprises Inc.	
MATERIAL	STEEL	DRAWN	DJM		ADAPTER FLANGE
FINISH	NONE	CHECKED			
		ENG APPR.			
		MFG APPR.			
		Q.A.			
DO NOT SCALE DRAWING		COMMENTS:		SIZE A PART. NO. WPX819 REV. -	
		SCALE:1:2	WEIGHT:	SHEET 1 OF 1	