

REVISIONS				
ZONE	REV.	DESCRIPTION	DATE	APPROVED

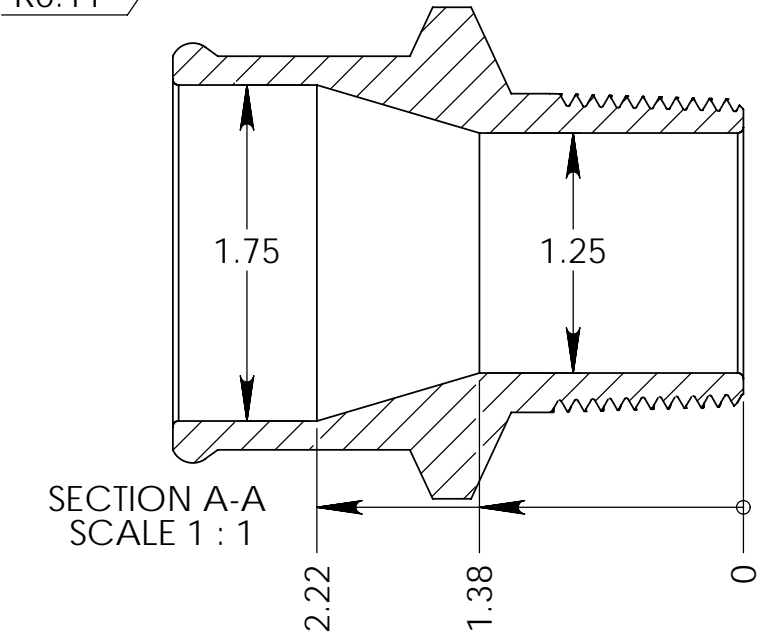
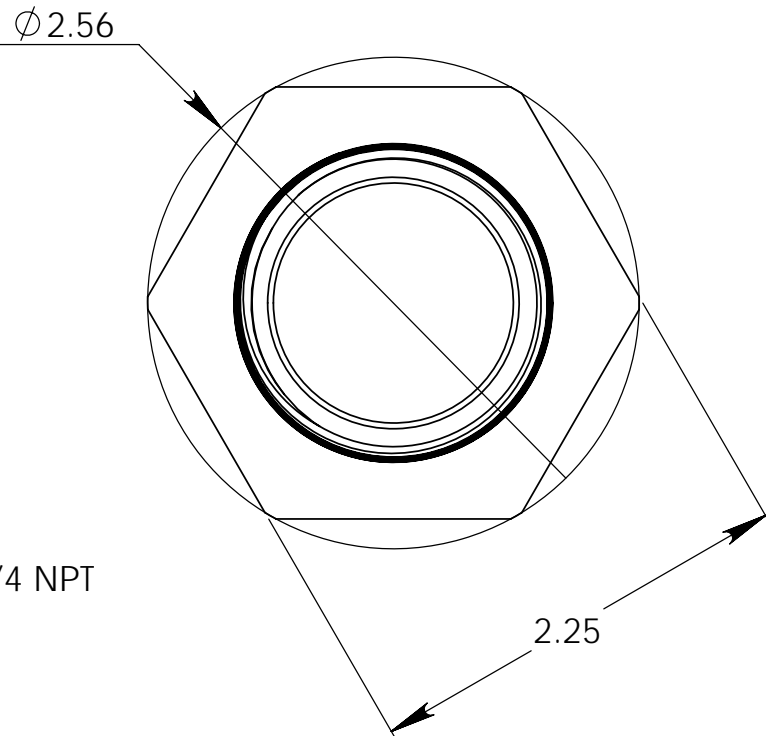
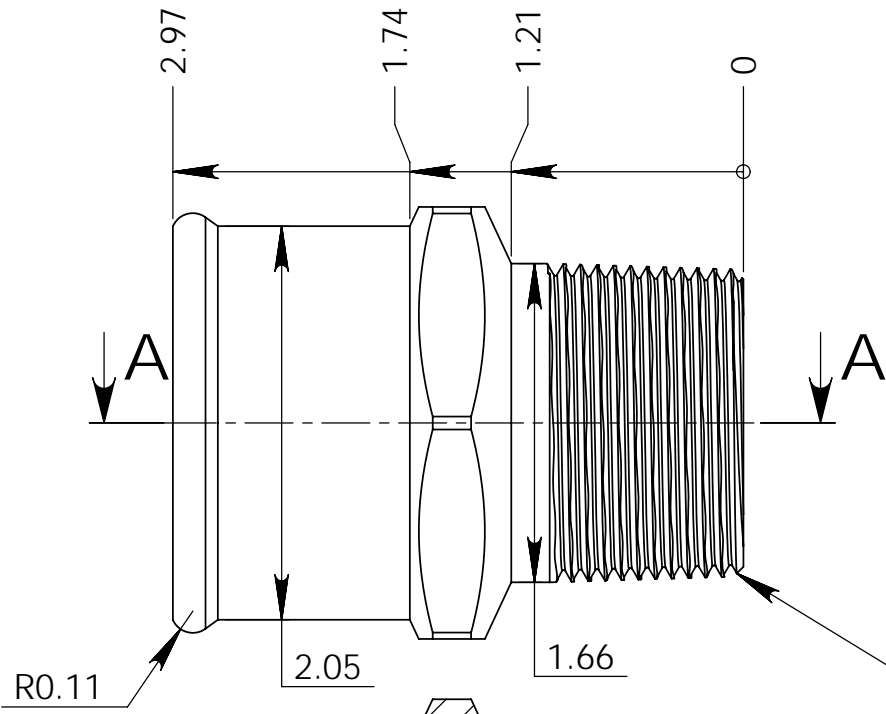

SECTION A-A
SCALE 1 : 1

- INSTALLATION NOTE:
1. USE TEFLON TAPE OR APPROPRIATE SEALANT
 2. DO NOT OVER-TORQUE

DIMENSIONS ARE IN INCHES TOLERANCES: FRACTIONAL ± 1/2 DEGREE ANGULAR: MACH ± BEND ± TWO PLACE DECIMAL ± .015 THREE PLACE DECIMAL ± .005	NAME	DATE	Meziere Enterprises Inc. ADAPTER, 1-1/4" NPT TO 2" HOSE	
	DRAWN	KJM		10-18-11
	CHECKED			
	ENG APPR.			
	MFG APPR.			
MATERIAL	6061		Q.A.	
FINISH	TYPE II BLK ANO		COMMENTS:	
DO NOT SCALE DRAWING	SIZE	PART. NO.	REV.	
	A	WPX814	-	
	SCALE:1:2	WEIGHT:	SHEET 1 OF 1	