

|      |      | REVISIONS   |      |          |
|------|------|-------------|------|----------|
| ZONE | REV. | DESCRIPTION | DATE | APPROVED |
|      |      |             |      |          |
|      |      |             |      |          |

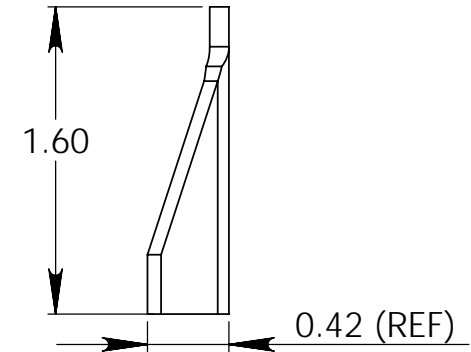
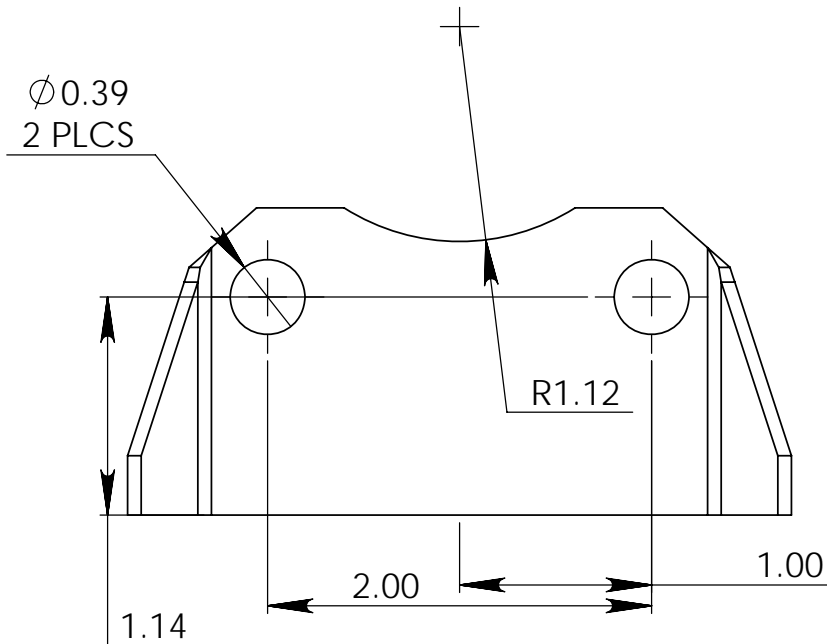
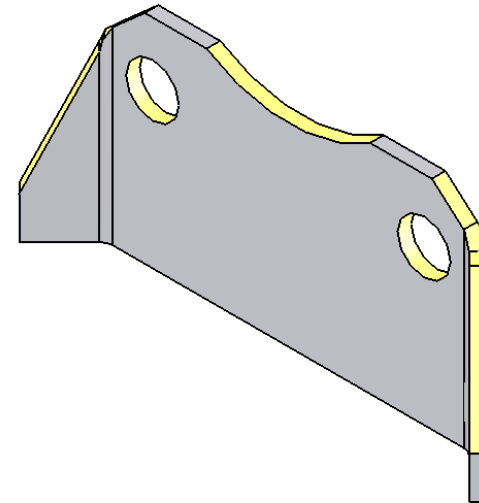
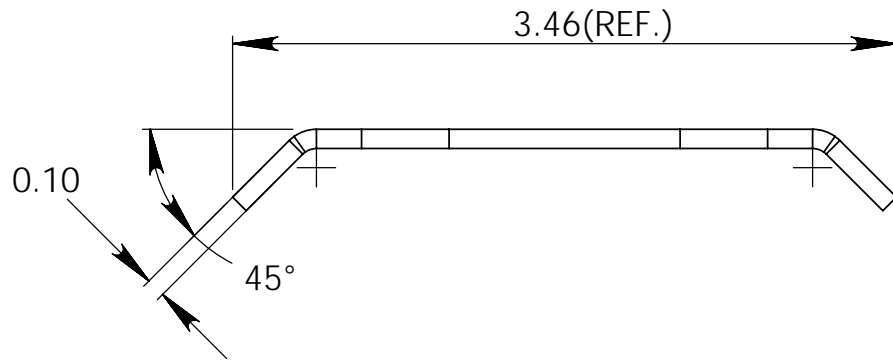

|  |            |           |              |   |         |
|--|------------|-----------|--------------|---|---------|
| DIMENSIONS ARE IN INCHES<br>TOLERANCES:<br>FRACTIONAL ± 1/2 DEGREE<br>ANGULAR: MACH ± BEND ±<br>TWO PLACE DECIMAL ± .015<br>THREE PLACE DECIMAL ± .005 |            | NAME      | DATE         | Meziere Enterprises Inc.<br><br><b>MOUNTING BRACKET</b> |         |
|  |            | DRAWN     | DJM          |   | 3-19-12 |
|  |            | CHECKED   |              |   |         |
|  |            | ENG APPR. |              |   |         |
|  |            | MFG APPR. |              |   |         |
| MATERIAL   | 4130 STEEL | Q.A.      |              |   |         |
| FINISH   | NONE       | COMMENTS: |              |   |         |
| DO NOT SCALE DRAWING   |            |           |              |   |         |
| SIZE   | PART. NO.  |           | REV.         |   |         |
| A  | WPX801     |           | -            |   |         |
| SCALE:1:1  | WEIGHT:    |           | SHEET 1 OF 1 |   |         |